

Single 10/100 BASE-TX Filtered Connector Module Support Auto MDIX MODEL NO. : RJC-248TC1

Features

- ⊙ RoHS Compliant
- ⊙ Fully shielded magnetics protect data from internally generated digital noise
- ⊙ Reduces the overall length of the signal path for improved common mode performance
- ⊙ Implements full common mode termination scheme with used and unused twisted pairs
- ⊙ Meets IEEE802.3 Baseline Wander Compensation specification
- ⊙ Integrates high voltage capacitor to chassis ground
- ⊙ Supports all major transceivers with matched turns ration and complete integration of specified termination
- ⊙ Design for 100base-tx transmission over UTP-5 cable
- ⊙ Operating TEMP. range : -40°C to +85°C
- ⊙ Storage TEMP. range : -55°C to +125°C
- ⊙ Primary OCL inductance : 350μH MIN. at 100KHz/100mV with 8mA DC bias.

Typical Performance Characteristics@ 25°C

Insertion Loss (dB MAX)	Return Loss (dB Min @100±15Ω)				Differential to Common Mode Rejection (dB MIN)	Cross talk (dB MIN)					CMRR (dB MIN)	Isolation Voltage (Vrms min)
	MHz	MHz				MHz	MHz	MHz	MHz	MHz		
1~100	1~30	40	50	60~80	1~100	20	40	60	80	100	1~100	1500
-1.0	-16	-14	-12	-10	-33	-47	-40	-37	-35	-33	-30	

Schematic Design on MDI Interface Circuitry

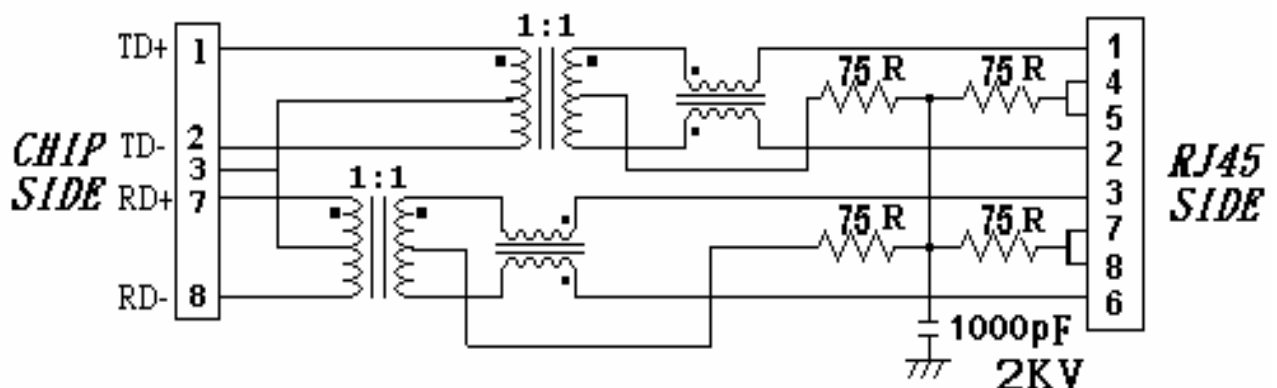

MODEL NO. : RJC-248TC1

Dimension: mm

TOLERANCE:±0.15 (unless otherwise specified)

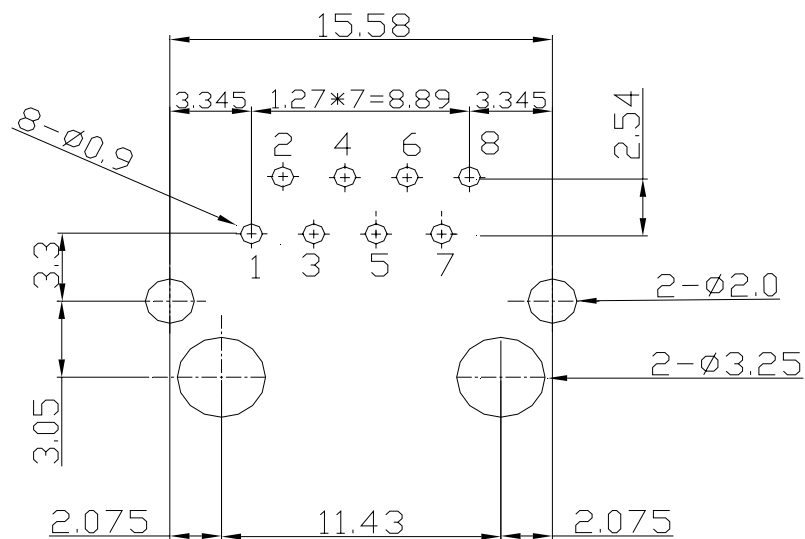
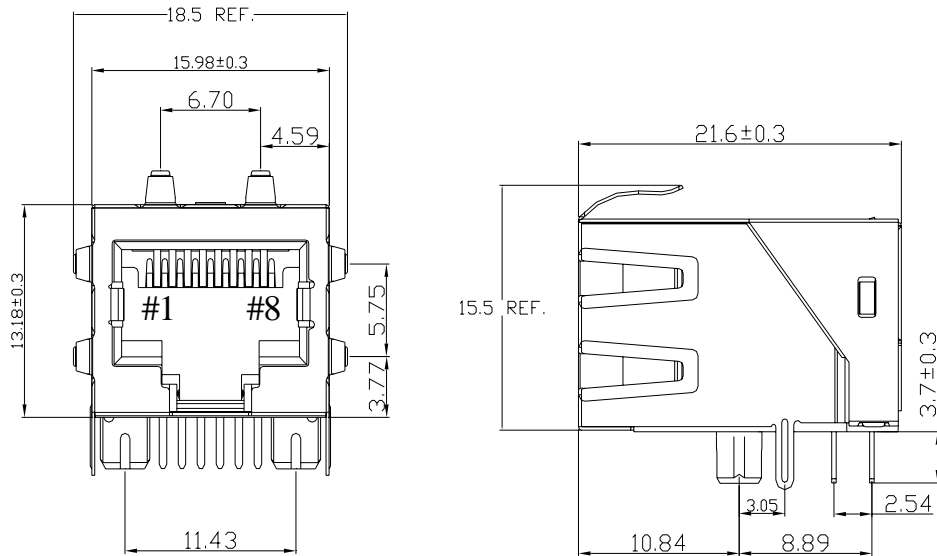

RECOMMENDED P.C.B LAYOUT
COMPONENT SIDE OF BOARD



NUMBER : RD-SDRJC-248TC1
DATE : 2007/05/23 R(REV:A6)

MODEL NO. : RJC-248TC1

Ordering Information

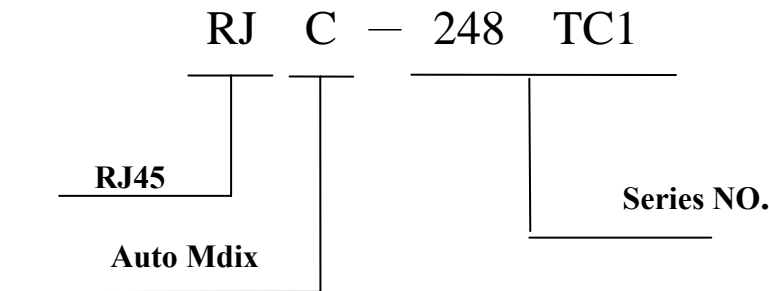

Requirements :

1. Design and Construction

Product shall be of design, construction and physical dimensions specified on applicable product drawing.

2. Materials and Finish

A. Contact:

RJ Contact : Phosphor Bronze, Thickness=0.30mm

Finish : Contact Area : 6 μ "min. Gold over 50 μ "min. Nickel

RJ Joint Contact : SPCC, Thickness=0.3mm

Finish : 80 μ "min. Sn over 50 μ "min. Nickel

B. Plastic Part :

(1) Set Housing : Thermoplastic, LCP, Black

UL FILE NO. : E107536

Manufacturer : SHIKONG SYNTHETIC FIBERS CORP.

Grade : E202G30BK

Flame Class : UL 94V-0

(2) Insert : Thermoplastic, PBT, Black

UL FILE NO. : E107536

Manufacturer : SHIKONG SYNTHETIC FIBERS CORP.

Grade : E202G30BK

Flame Class : UL 94V-0



NUMBER : RD-SDRJC-248TC1
DATE : 2007/05/23 R(REV:A6)

MODEL NO. : RJC-248TC1

(3) Spacer : Thermoplastic, PBT, Black

UL FILE NO. : E107536

Manufacturer : SHIKONG SYNTHETIC FIBERS CORP.

Grade : E202G30BK

Flame Class : UL 94V-0

C. Shield Material :

Cartridge t=0.25mm

10 μ "-20 μ " Thick Nickel over Brass.

3. Ratings

(1) Voltage rating : 125 VAC

(2) Current rating : 1.5A

Durability :

(1) 1000 cycles with no function damage for RJ-45 . Abnormalities shall be present after the test.

(2) Low Level Contact Resistance : $\Delta R=30m\Omega$ maximum (final)

(3) The sample should be mounted in the tester and fully mated and unmated 500 times per hour at the rate of 25mm/min.EIA-364-09C.

MODEL NO. : RJC-248TC1

1. Unit weight :5.7 grams
2. package : 100 pcs / tray / 0.61 kgms
3. Carton : 1000 pcs / 10 layers of tray
4. Gross weight : 6.6455 kgms

Package drawing:

